

WELCON

Servo Drive

Hardware Manual



WER-D048/30-FS04F7



Precautions

- Please read this manual carefully before installing and commissioning.
- WELCON SYSTEMS assumes no responsibility whatsoever for any loss or damage arising out of use for any purpose.

Copyright Notice

© 2023 WELCON Systems. All rights reserved.

Copyright in this document is reserved exclusively by WELCON SYSTEMS. That is, the owner of the text, images, and all other materials listed in this document is WELCON SYSTEMS. Therefore, the unauthorized distribution, transfer, or duplication of the text, images, and other materials in this document without the written permission of the copyright holder, WELCON SYSTEMS, is prohibited.

Product Name for welcon Drive

WE2S-D024 / 01-FS0057-E

Product Type

- WE** WELCON Standard
- ** User Code (only for customized order)

Drive Shape

- R** Rectangle Type Board
- C** Circle Type Board
- M** Miniature Board
- 2S** 2-Axis Slot Type (Backboard necessary)
- 2A** 2-Axis Stand-Alone Type

Power

- D** DC
- A** AC

Voltage

- 024** 12~24V
- 048** 12~48V
- 310** 12~310V

Continuous Current

- P3** 0.3A rms
- P5** 0.5A rms
- 01** 1A rms
- 03** 3A rms
- 10** 10A rms
- 25** 25A rms

Feedback Sensor (Hexadecimal)

Bit0	Incremental Encoder	Bit4	Sin/Cos Encoder	Bit8	Potentiometer
Bit1	Dual Incremental Encoder	Bit5	BISS/SSI Interface Encoder	Bit9	SPI
Bit2	Separated Digital Hall Sensor	Bit6	Analog Hall Sensor	Bit10	EnDat
Bit3	Shared Digital Hall Sensor	Bit7	Tamagawa/Panasonic Encoder	Bit11	PWM

Ex) 0057= 0000 0000 0101 0111

Incremental(Bit0) + Dual Incremental (Bit1) + Separated Digital Hall (Bit2) + Sin/Cos (Bit4) + Analog Hall (Bit6)

Communication

- E** EtherCAT
- C** CAN
- R** RS-485



Room 812, 555, Byeolmang-ro, Danwon-gu, Ansan-si, Gyeonggi-do, 15434, Republic of Korea
 TEL 031.417.6735 FAX 031.417.6736
 ican6070@welconsystems.com



CONTENTS

Precautions.....	2
Copyright Notice	2
CONTENTS.....	4
1. Safety Information	5
Use environment	6
2. Technical Information	7
2.1. Mechanical Data	7
2.2. Electrical Data	8
3. Wiring	10
3.1. Tools.....	10
3.2. Connections	10
3.3. Regenerative resistance.....	11
3.4. Main Power	12
3.5. Motor UVW.....	13
3.6. Digital Encoder (Port A)	14
3.7. Digital Encoder (Port B).....	15
3.8. Analog Encoder.....	16
3.9. Serial Encoder	17
3.10. GPIO.....	18
3.11. EtherCAT	20
3.12. CAN	21
3.13. RS-485.....	22
3.14. USB	24

Question : www.welconsystems.com

1. Safety Information

- Safety accidents and damage to the product may occur, so be sure to read the safety instructions before use and use it correctly.

Warnings

- 전원이 켜진 상태에서 서보 드라이브 주 전원을 연결/분리하지 마십시오.
Do not connect/disconnect the main power of the servo drive while the power is on.
- 전원이 켜진 상태에서 서보 드라이브 엔코더 케이블 및 I/O를 연결/분리하지 마십시오.
모터 및 서보 드라이브의 고장 원인이 될 수 있습니다.
Do not connect/disconnect the servo drive encoder cable and I/O while the power is on. Motor and servo drive may be damaged.
- 전원 케이블은 모터가 움직이지 않을 때도 고전압을 전달할 수 있습니다.
The power cable can carry high voltage even when the motor is not moving.
- 서보 드라이브의 메인 전원은 드라이브 사양에 맞춰 정확히 입력되어야 합니다.
드라이브 파손 및 고장의 원인이 될 수 있습니다.
The main power of the servo drive must be accurately input according to the drive specifications. It may cause damage to the drive
- 서보 드라이브 U, V, W 출력 단자에 전원을 직접 접속하지 마십시오.
Do not connect power directly to the servo drive U, V, W output terminals.
- 서보 드라이브 전원을 차단한 후 캐패시터가 완전히 방전된 후 전원을 분리해 주십시오.
After turning off the servo drive power, disconnect the power after the capacitor is completely discharged.

 **Cautions**

- U, V, W 케이블과 Encoder 케이블은 반드시 분리하여 배선해 주십시오.
Be sure to separate U, V, W cables and encoder cables before wiring.
- 전원 차단 후 U, V, W 케이블과 Encoder 케이블 배선작업을 진행하십시오.
After turning off the power, proceed with wiring the U, V, W cables and encoder cables.
- 떨어뜨리거나 강한 충격을 가하지 마십시오.
Do not drop it or subject it to strong impact.
- 가연성 물질, 물 근처는 설치를 하지 말아주십시오.
Do not install near flammable substances or water.
- 서보 드라이브 내부에 피복이나 구리선 등이 들어가지 않도록 해 주십시오.
Make sure that no sheath or copper wire gets inside the servo drive.
- Encoder 케이블은 실드 케이블 사용을 권장합니다.
It is recommended to use shielded cables for encoder cables.
- EtherCAT 케이블은 CAT.6 이상의 케이블 사용을 권장합니다.
For EtherCAT cables, it is recommended to use CAT.6 cables.
- 초기 전원 투입 전 모터의 U, V, W 및 Encoder 케이블 등을 확인하여 주십시오.
Check the U, V, W and encoder cables of the motor before turning on the power.
- 노이즈 방지를 위해 Encoder 케이블 및 U, V, W 및 전원 FG 접속을 권장합니다.
It is recommended to connect the encoder cable and U, V, W and power FG to prevent noise.
- 케이블 연결 및 연결 해제 시 커넥터가 기판에서 분리되지 않도록 주의하여 주십시오.
Be careful not to separate the connector from the board when connecting or disconnecting the cable.

Use environment

환경	조건
Operating Temperature	0 °C to 50 °C
Maximum Humidity	90[%] RH
Operating Place	A place free of iron, flammable gas, dust, etc.

2. Technical Information

2.1. Mechanical Data

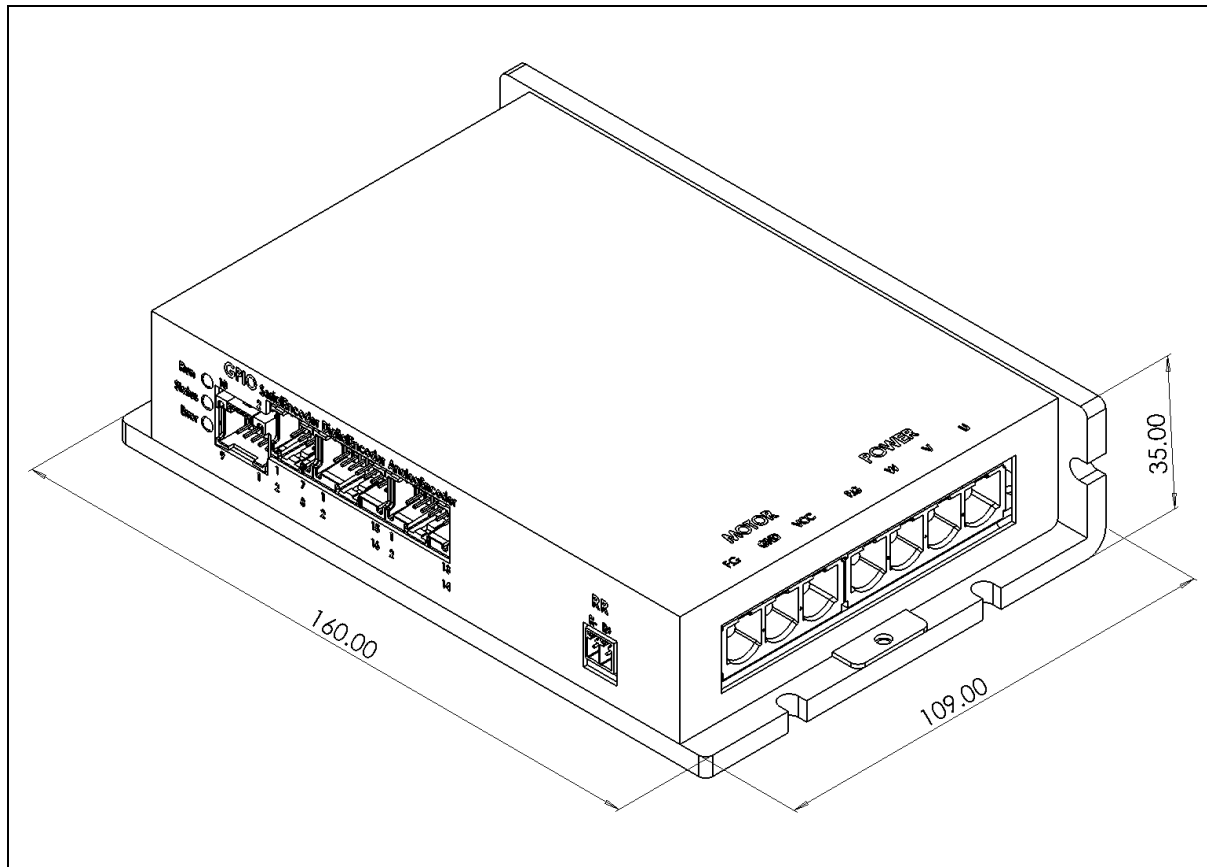

Item	Unit	Description
Weight	g	682
SIZE (L x W x H)	mm	160 * 109 * 35
Fastener	M3	

[*For details, please refer to the 3D Modelling on the homepage.](#)

2.2. Electrical Data

WER-D048/30-FS04F7	
Ratings	30
Continuous Output Current A[rms]	30
Peak Output Current A[rms]	60
Basic Specifications	
Feature	Specification
Motors	DC/BLDC/PMSM/VCM Rotary servo motors, Linear servo motors
Current(Torque) Control	Control Periodic 24KHz
	Control Loop PI + Feed-forward
Velocity & Position Control	Control Periodic 2KHz
	Control Loop Cascade P/PI + Feed-forward
	Filters First order low pass filter, Four notch filters, First order adaptive windowing filters
Reference Command	Current/Velocity/Position USB, CAN(CANopen), EtherCAT(CoE, FoE), RS-485
Auto Tuning	Method Automatic self-configuration and optimization of motor phasing, wires, current loop, velocity control loop.
GUI	User Interface WELSS(WelconServoStudio), Setting, Drive, Motor, Feedback, I/O, Motion
Input Voltage	12~48VDC
Protective Functions	Under- and over-voltage, Over-current, Over-load(with I ² T), Drive over-temperature
Environment	Ambient temperature: Operation 0-50°C, Storage 0-70°C Humidity: 10-90%, Vibration: 1.0g
Compliance Standard	CE
Communication*	
Feature	Specification
USB	Baud rate: up to 3Mbps, Maximum cable length: 3m
CAN*	Bit rate: 125kbps ~ 1Mbps
EtherCAT*	100Mbps Communication cycle time: up to 500μs(CSV, CSP mode), up to 250μs(CST mode)
RS-485*	Baud rate: 9200bps ~ 3Mbps

I/O		
Feature	Specification	
Analog Input	Quantity	1
	Voltage Range	Analog ± 10 VDC differential
	Input Resolution	14 bit
Digital Input	Quantity	6
	Signal	Configurable. Opto-isolated
	Voltage	24V
Digital Output	Quantity	2
	Signal	Configurable. Opto-isolated.
	Voltage	24V
	Max. Output Current	40mA
Brake	Use one of digital outputs (40mA)	
Motor Feedback*		
General	Supply Voltage	5VDC
Incremental Encoder	Signal	CH1 : A-quad-B with or without index, RS422, Differential CH2 : A-quad-B with or without index, Single-ended
	A-quad-B Max Input Frequency	10MHz (before quadrature)
Digital Hall Sensor	Signal	Single-ended
	Type	Separated hall sensor
Analog Hall Sensor*	Signal	0~5V, Single-ended
	Sampling Frequency	24KHz
Sin/Cos Encoder*	Signal	-0.7~+0.7V at 2.5V, Differential
	Sampling Frequency	24KHz
Serial Encoder	Type	SSI, BiSS-C, Tamagawa, Panasonic, EnDat2.2
	Bite rate	0.5Mbps, 1Mbps, 2Mbps, 2.5Mbps, 5Mbps

* Optional (Refer to product code)

3. Wiring

3.1. Tools

Tool	Manufacturer	Part Number
Hand crimp Tool	MOLEX	63811-6300

3.2. Connections

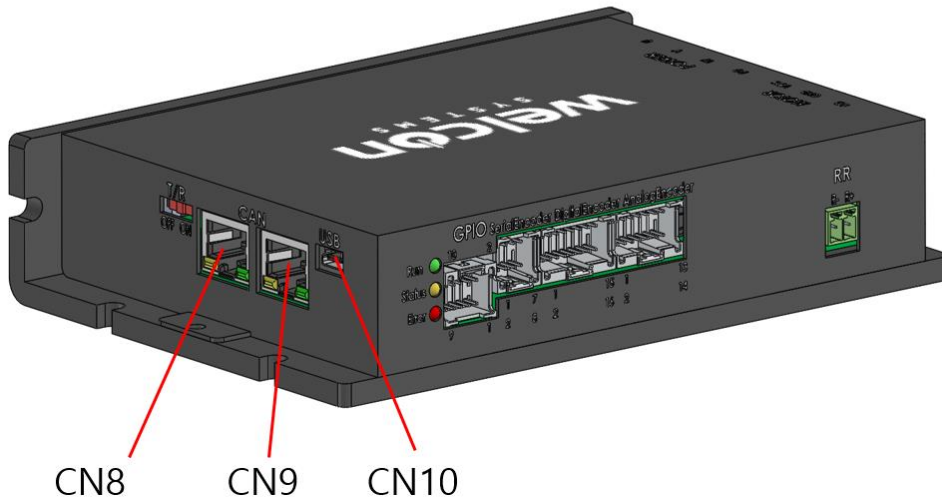
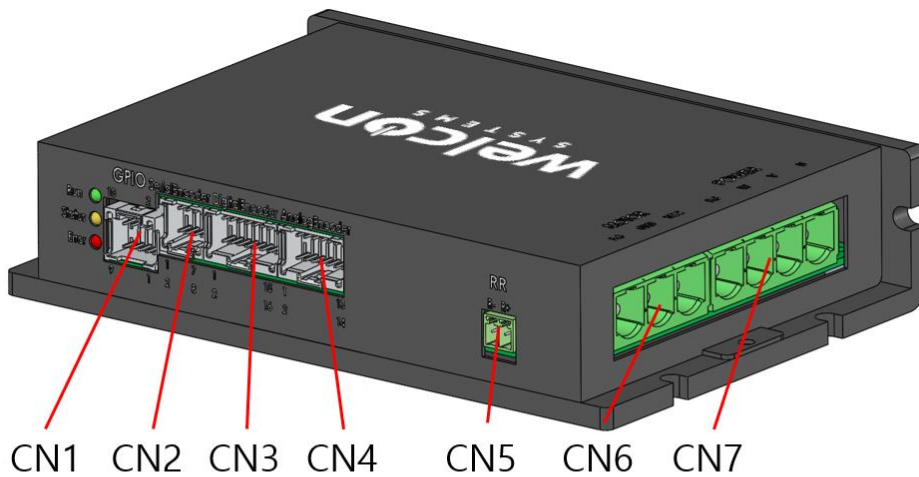

Connector	Function	Connector	Function
CN1	GPIO	CN6	Main Power
CN2	Serial Encoder	CN7	Motor UVW
CN3	Digital Encoder	CN8	CAN / RS-485 / EtherCAT IN
CN4	Analog Encoder	CN9	CAN / RS-485 / EtherCAT OUT
CN5	Regenerative resistance	CN10	USB

3.3. Regenerative resistance

Dinkle_EC350V-2P

Dinkle_ECH350R-02P		J702
Pin	Input Power	
1	R+	
2	R-	



- Be sure to connect the regenerative resistor after changing the regen clamp cut-off voltage value(Object Index : 0x5013) using WELSS UI.
- On systems with large inertia, do not make large speed changes all at once.

3.4. Main Power

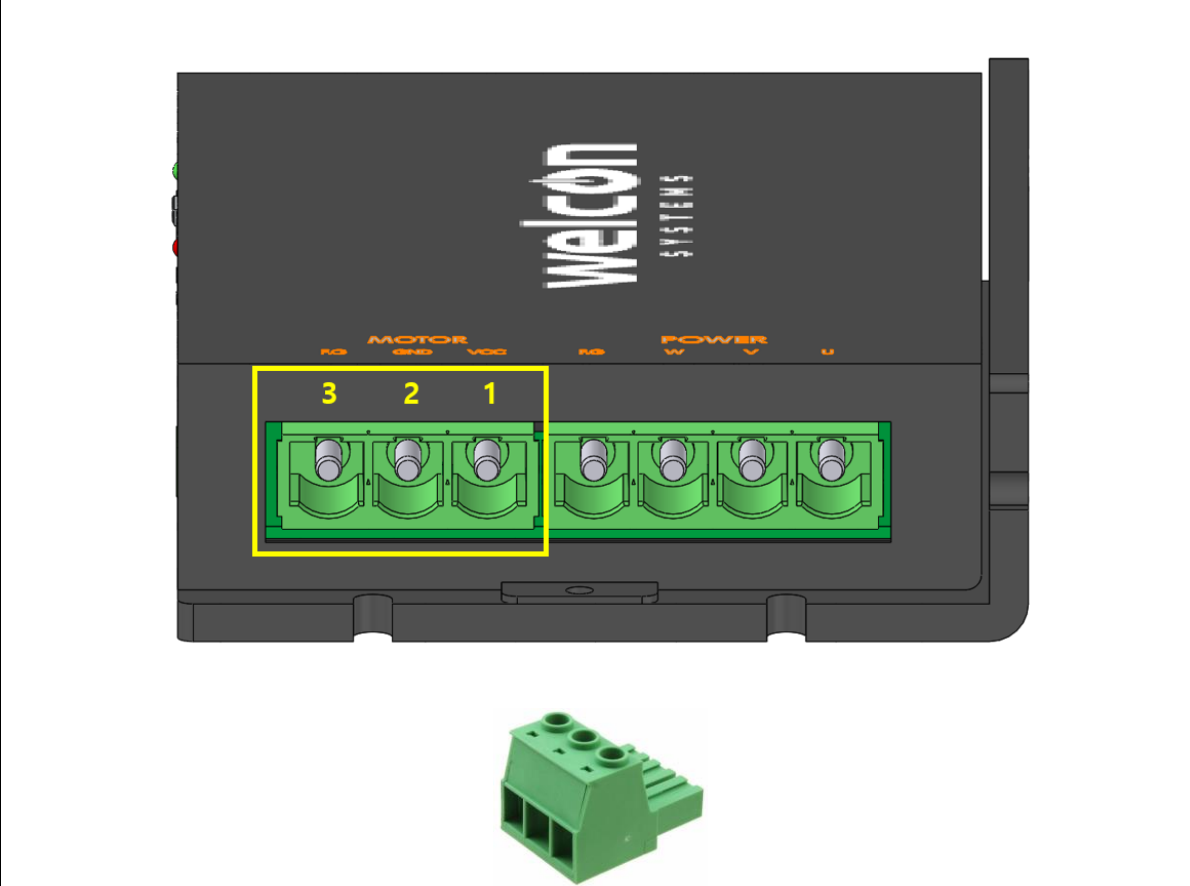

Phoenix Contact_1913510

Phoenix_Contact 1913659		J701
Pin	Signal	Input Power
1	VCC	12~48VDC
2	GND	GND
3	FG	FG



- Do not connect/disconnect the servo drive while the power is on.
- Before applying power, make sure that the DC supply is within the specified range.
- make sure the proper plus and minus connections are in order.

3.5. Motor UVW

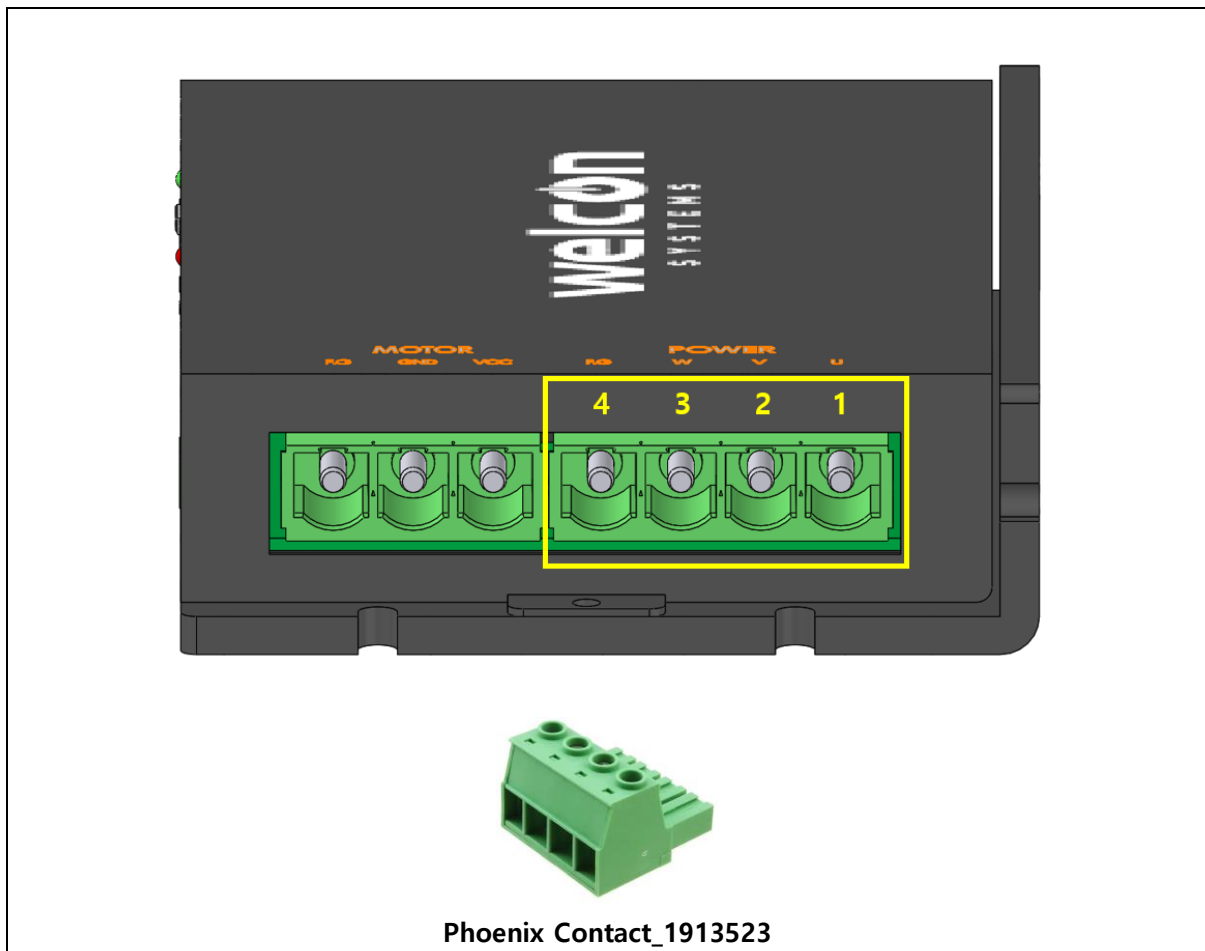

Phoenix Contact_1913523

Phoenix Contact_1913662		J801
Pin	Signal	
1	U (VCM or DC Motor : +)	
2	V (VCM or DC Motor : -)	
3	W	
4	FG	

3.6. Digital Encoder (Port A)

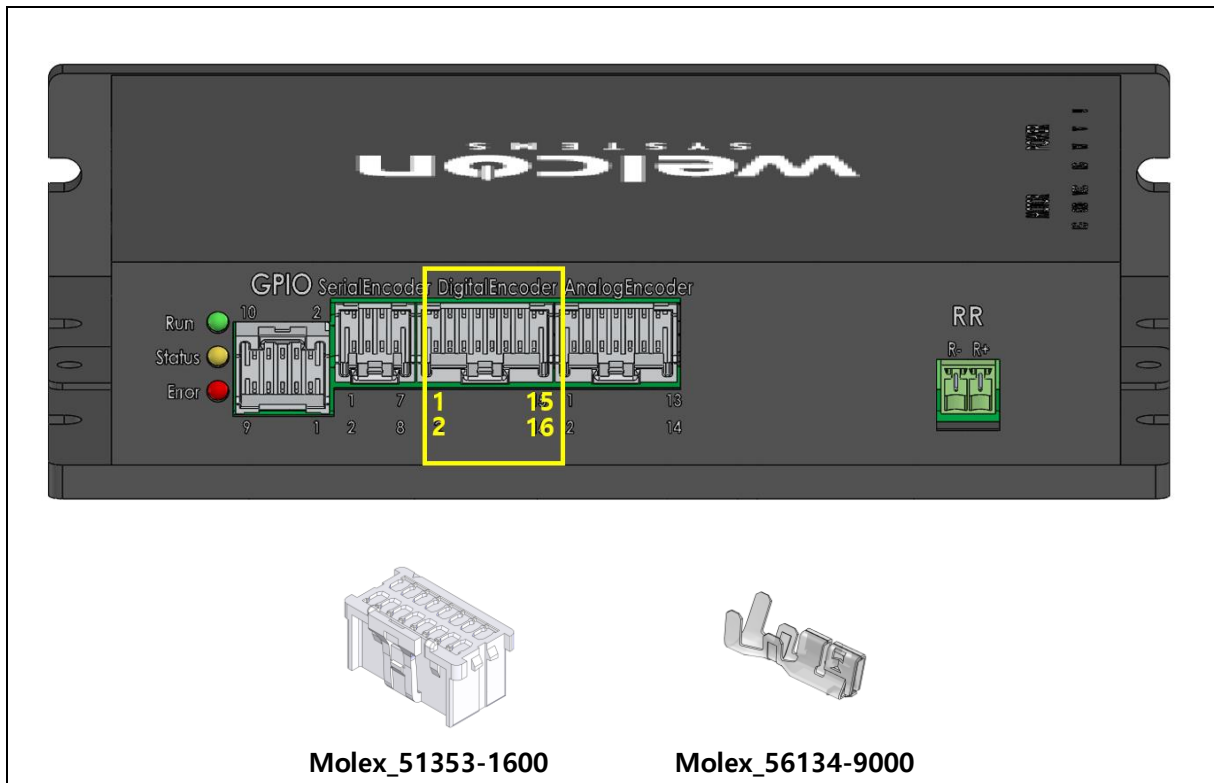

Molex_55959-1630		J201
Pin	Signal	
1	5V	
2	GND	
3	Encoder A+	
4	Encoder A-	
5	Encoder B+	
6	Encoder B-	
7	Encoder I+	
8	Encoder I-	
9	Hall U	
10	Not used	
11	Hall V	
12	Not used	
13	Hall W	
14	Not used	
15	FG	
16	GND	

3.7. Digital Encoder (Port B)

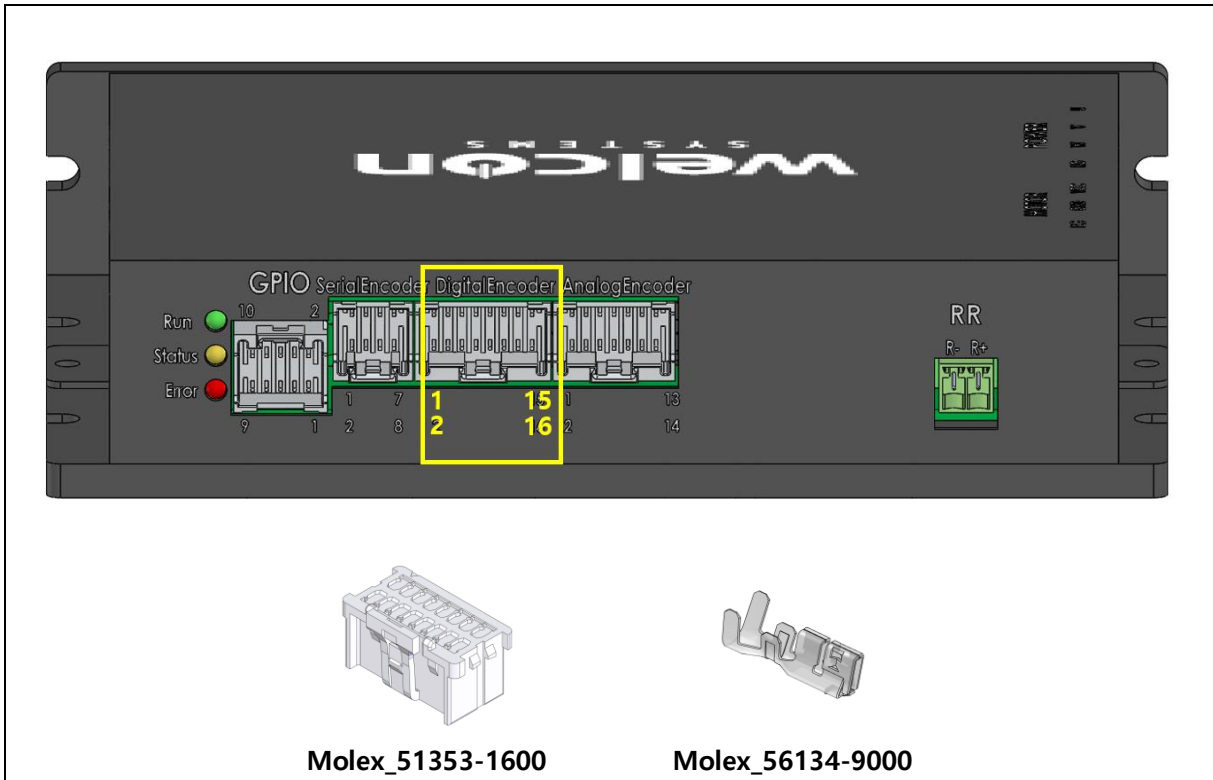

Molex_55959-1630		J201
Pin	Signal	
1	5V	
2	GND	
3	Not Used	
4	Not Used	
5	Not Used	
6	Not Used	
7	Not Used	
8	Not Used	
9	Hall U	
10	Encoder A	
11	Hall V	
12	Encoder B	
13	Hall W	
14	Encoder I	
15	FG	
16	GND	

* When using Dual Feedback, only Hall Sensor A can be selected in WELSS UI.

3.8. Analog Encoder

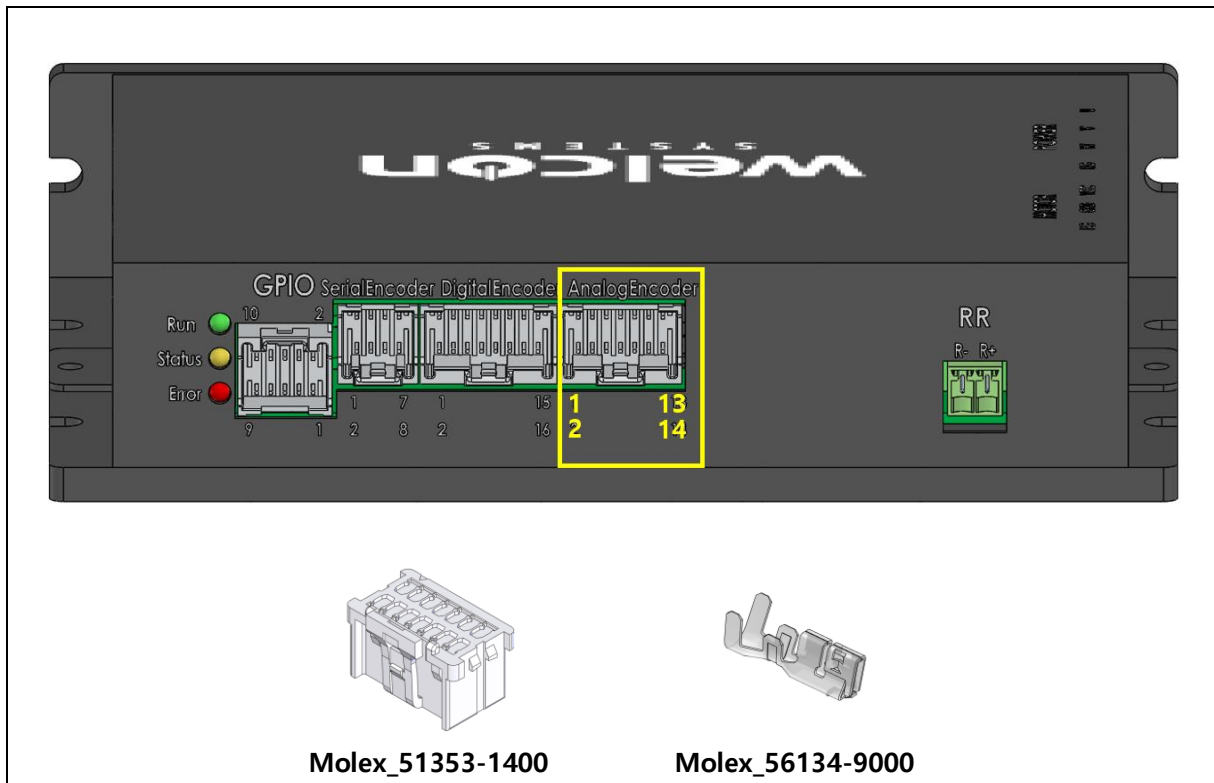

Molex_55959-1430		J901
Pin	Signal	
1	SIN+	
2	SIN-	
3	COS+	
4	COS-	
5	REF+	
6	REF-	
7	5V	
8	GND	
9	FG	
10	Analog Hall U	
11	Analog Hall V	
12	Analog Hall W	
13	Analog Input+	
14	Analog Input-	

3.9. Serial Encoder

Molex_55959-0830		J801
Pin	Signal	
1	BISS_DATA+ / RS485_RTX+	
2	BISS_DATA- / RS485_RTX-	
3	BISS_CLK+	
4	BISS_CLK-	
5	Not Used	
6	Not Used	
7	5V	
8	GND	

3.10. GPIO

The diagram shows the terminal block of a WELCON servo drive. The GPIO section is highlighted with a yellow box and numbered 1 through 10. To the left of the terminal block are three LEDs: Run (green), Status (yellow), and Error (red). To the right is a terminal block labeled 'RR' with terminals 'R-' and 'R+'. The terminal block has 16 pins, with labels 1, 7, 1, 15, 1, 13 on the top row and 2, 8, 2, 16, 2, 14 on the bottom row.

Below the diagram are two connector images: Molex_51353-1000 and Molex_56134-9000.

Molex_55959-1030		J901
Pin	Signal	
1	GPI 0	
2	GPI 1	
3	GPI 2	
4	GPI 3	
5	GPI 4	
6	GPI 5	
7	GPI_COMMON	
8	GPO 0	
9	GPO 1	
10	GPO_COMMON	

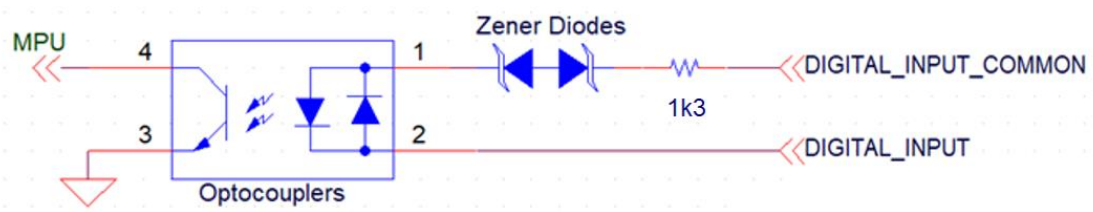

<Digital Input Circuit>

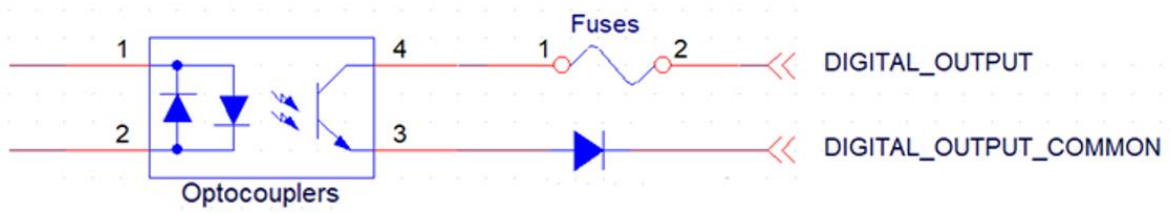

<Digital Output Circuit>

3.11. EtherCAT

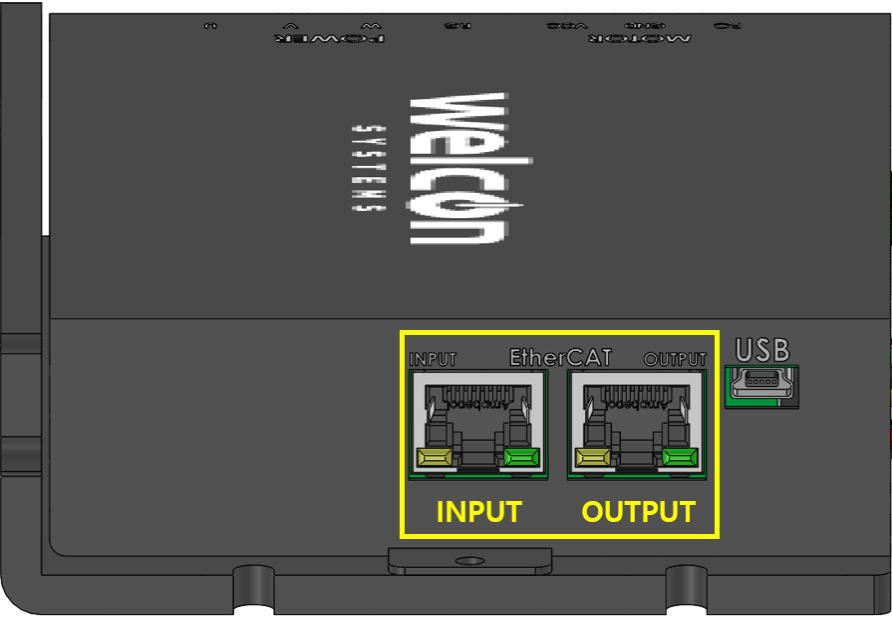
Fieldbus Type	Product Number
EtherCAT	WER-D048/30-FS04F7-E
	
Meritec_N3J11-017-02	
Pin	Signal
1	EtherCAT Tx+
2	EtherCAT Tx-
3	EtherCAT Rx+
4	NC
5	NC
6	EtherCAT RX-
7	NC
8	NC

3.12. CAN

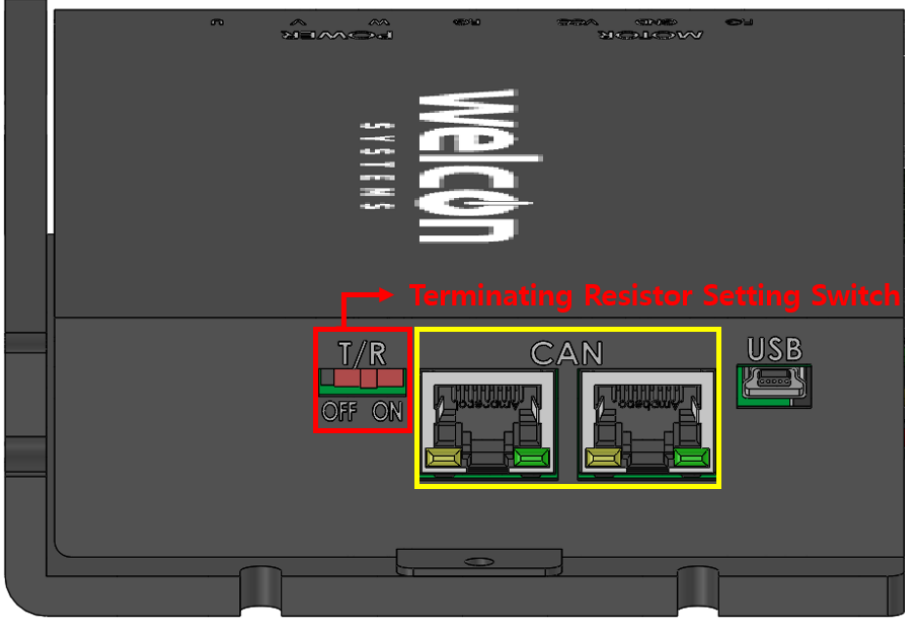
Fieldbus Type	Product Number
CAN	WER-D048/30-FS04F7-C
	
Meritec_N3J11-017-02	J102, J103
Pin	Signal
1	HIGH
2	LOW
3	GND
4	NC
5	NC
6	NC
7	NC
8	NC

3.13. RS-485

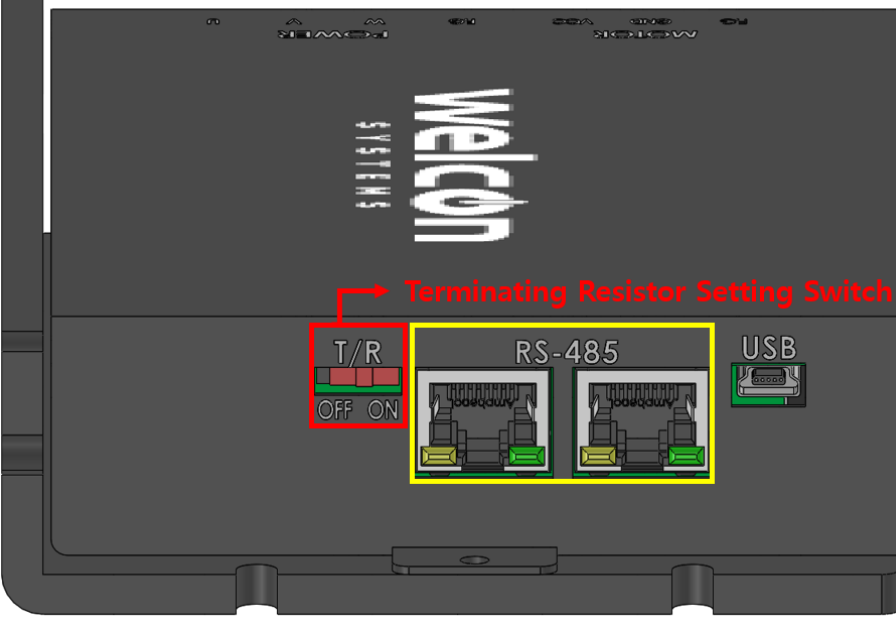
Fieldbus Type	Product Number
RS-485	WER-D048/30-FS04F7-R
	
Meritec_N3J11-017-02	J102, J103
Pin	Signal
1	RTX+
2	NC
3	GND
4	RTX-
5	NC
6	NC
7	NC
8	NC

- 종단 저항 설정 스위치를 이용하여 CAN or RS-485 신호선의 양 끝단에 종단 저항 연결
- Connect the terminating resistor to both ends of the CAN or RS 485 signal line using the terminating resistor setting switch.

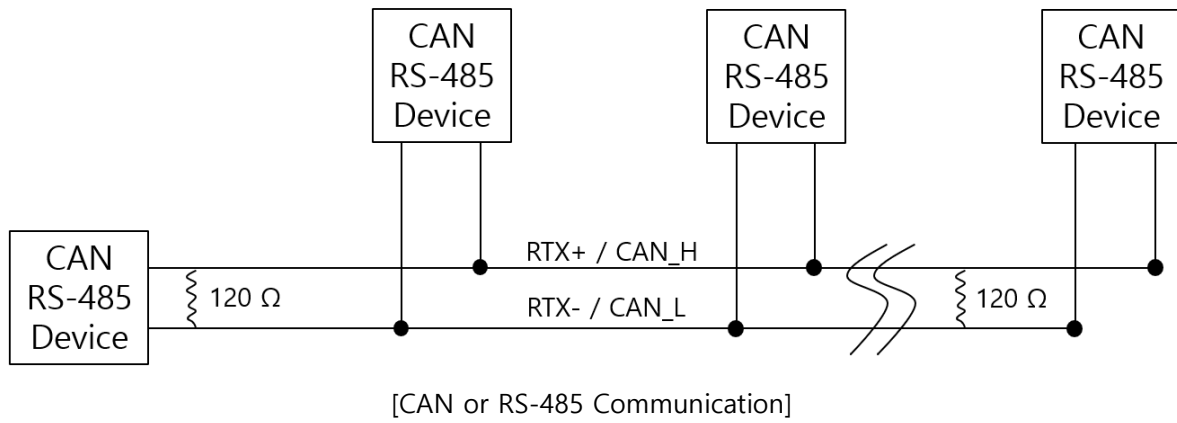

3.14. USB

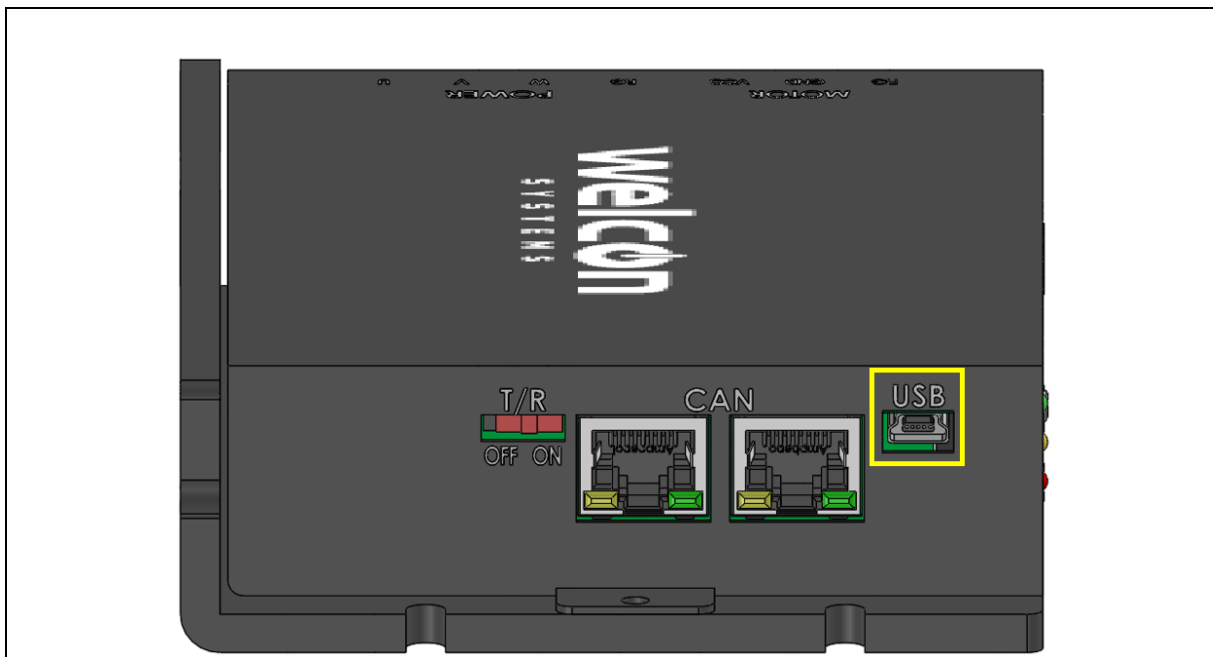

USB-Mini Type B (Keystone Model:937)		J101
Pin	Signal	
1	VBUS	
2	DM	
3	DP	
4	ID	
5	GND	
6	SHIELD	



© 2023 WELCON Systems. All rights reserved.

Copyright in this document is reserved exclusively by WELCON SYSTEMS. That is, the owner of the text, images, and all other materials listed in this document is WELCON SYSTEMS. Therefore, the unauthorized distribution, transfer, or duplication of the text, images, and other materials in this document without the written permission of the copyright holder, WELCON SYSTEMS, is prohibited.

WELCON SYSTEMS

(15434) Room 812, 555, Byeolmang-ro, Danwon-gu, Ansan-si, Gyeonggi-do, Republic of Korea

PHONE +82 31 417 6735

FAX +82 31 417 6736

www.welconsystems.com